



EUR 2 Pallet

1200 x 1000 x 162

The EUR 2 pallet (1200 x 1000 x 162 mm) is sturdy, suitable for heavy loads and ideal for roller and chain conveyors thanks to its circumferential base frame. This pallet is mainly used in English-speaking countries. Quality-assured licensees ensure smooth processes in supply chains and automation. The global exchange system conserves resources and reduces CO₂ emissions.

Independent quality control

Accredited inspection organisations check compliance with the prescribed quality standards in accordance with UIC standard 435-5 (production) and UIC standard 435-4 (repair). The inspections are unannounced and documented.

Phytosanitary treatment

Compliance with the ISPM 15 standard is essential for the international movement of goods. Euro pallets are produced strictly in accordance with the IPPC specifications, although recognition varies from country to country. The plant protection authorities will provide further information.

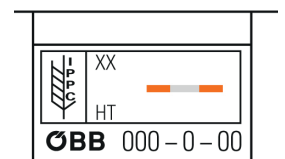

Repair

Defective EUR 2 pallets are repaired in EUR-certified facilities in an environmentally friendly manner. Each repaired pallet receives a repair identification nail with the company's logo and licence number.



Technical data

- Manufactured in accordance with **UIC standard 435-5**
- **9-17-135**: 9 blocks (solid wood or moulded chipboard), 17 boards (9 top boards, 3 cross boards and 5 bottom boards), 135 quality nails
- **Dimensions**: 1200 x 1000 x 162 mm (L x W x H)
- **Weight**: approx. 35 kg
- **Load capacity**: 1250 kg

1,200 mm side

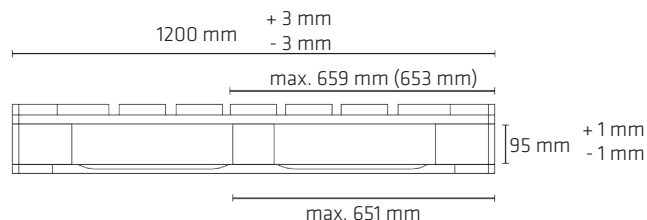

1,000 mm side

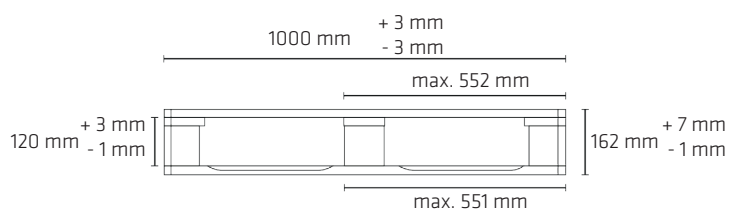

Top view

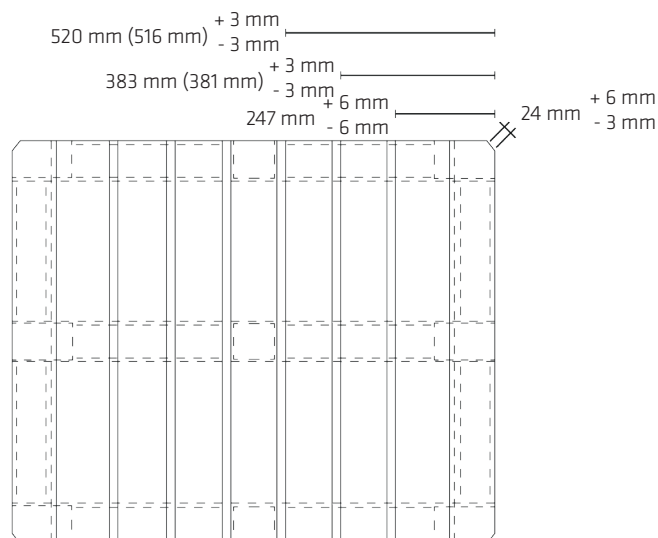

Labelling

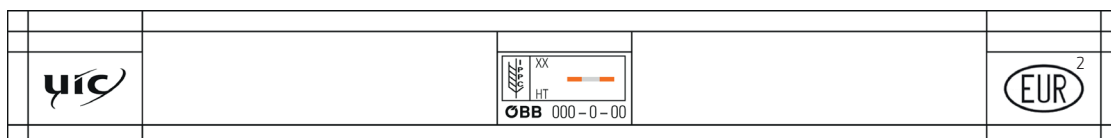

logo of the International Union of Railways (UIC)

tamper-proof inspection staple, IPPC mark, country code, registration number of the competent authority, HT marking for heat treatment, marking of the licensing railway (alphabetical or numerical), licence number of the licensee, year of production (one-digit), month of production (two-digit)

EUR in the Oval



ÖBB Inspection bracket stage 1 and stage 2

The owner of the trademark „EUR in the Oval“ is Rail Cargo Group, the rail freight transport subsidiary of ÖBB. The operating parent company of Rail Cargo Group is Rail Cargo Austria AG. As of 05/2025, Misprints and printing errors reserved, Pictures: © ÖBB/RCC David Payr, Rene Kern

eur-pallet.com

